

# MOROOKA EUROPE

HIGH EFFICIENCY IN MOTION



## MST200CR

Max. Payload 20T.

Full Rotating  
Rubber crawler carrier

CARRIER for SOFT, SANDY and  
ROUGH TERRAIN



360° rotation brings more security, less stress and fatigue to the driver



Easy Control with HST drive system

Unit : mm

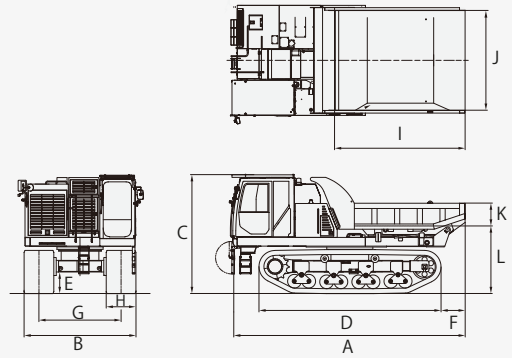

Model		MST200CR								
<b>PERFORMANCE</b>			<b>DUMP BODY</b>				<b>TANK CAPACITY</b>			
Maximum Payload	Kg	20,000	Overall Length	I	mm	3,800	Fuel Tank	ℓ	400	
Loading Capacity (Struck)	m <sup>3</sup>	7,8	Overall Width	J	mm	2,850	Hydraulic Tank	ℓ	280	
Speed1 Low	Km/h	7.3	Overall Height	K	mm	900	DEF Tank	ℓ	31,8	
Speed2 High	Km/h	11.2	Ground Clearance	L	mm	1,940	<b>DRIVE SYSTEM</b>			
Ground Pressure(empty)	kPa	45	<b>ENGINE</b>				<b>HST</b>			
Ground Pressure(Loaded)	kPa	81.4	Model	CAT 9.3B Tier 4 final Stage 5			<b>GRADEABILITY</b>			
<b>MACHINE DIMENSION</b>			Fully loaded: 27 % (15 degree) Continuous							
Machine Weight	Kg	24,740	Nominal Output/rpm	HP(kw)/rpm	415,7(310)/2,200		<b>OTHER</b>			
Overall Length	A	mm	Torque	N.m/min-1	1,904/1,400		<b>Cabin (ROPS/FOPS)</b> <b>Joystick control</b> <b>Hardox Dump Body</b> <b>Eco-mode</b> <b>Auto Deceleration</b> <b>Surround view camera</b>			
Overall Width	B	mm	<b>HYDRAULIC PUMP</b>							
Overall Height	C	mm	Main Pump		2x variable displacement axial piston pump					
Wheelbase	D	mm	Pilot pump		1x gear pump					
Min. Ground Clearance	E	mm	<b>HYDRAULIC MOTOR</b>							
Front Overhang	F	mm	Travel Motor		2x variable displacement axial piston motors					
Crawler Distance	G	mm	Swing Motor		1x axial piston motor					
Crawler Width	H	mm								
Crawler Size		mm	850x 175x 64							

Remarks: Specification may be changed without any notice.

**MOROOKA EUROPE**

Im Neugrund 14  
64521 Gross-Gerau, Germany  
Tel: +49 (0)61529778-0  
Fax: +49 (0)61529778-15  
Web: [www.morookaeurope.com](http://www.morookaeurope.com)

Contact