

MOROOKA EUROPE

HIGH EFFICIENCY IN MOTION



MST110CR

Max. Payload 11T.

**Full Rotating
Rubber crawler carrier**

**CARRIER for SOFT, SANDY and
ROUGH TERRAIN**



360° rotation brings more security, less stress and fatigue to the driver



Easy Control with HST drive system

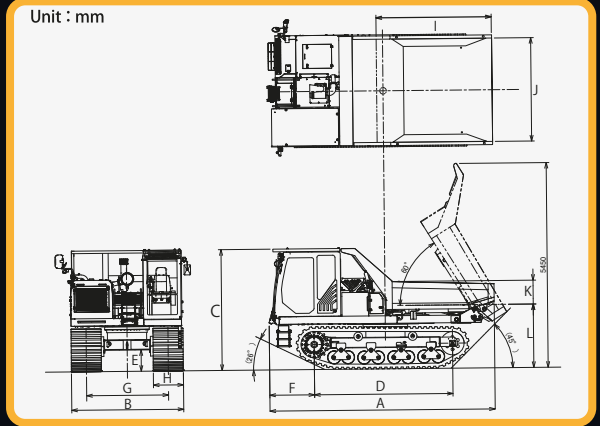

Model		MST110CR									
PERFORMANCE				DUMP BODY				TANK CAPACITY			
Maximum Payload	Kg	11,000	Overall Length	I	mm	3,050	Fuel Tank	ℓ	300		
Loading Capacity (Struck)	m ³	4.36	Overall Width	J	mm	2,750	Hydraulic Tank	ℓ	154		
Speed1 Low	Km/h	7.6	Overall Height	K	mm	635	DEF Tank	ℓ	32		
Speed2 High	Km/h	11.8	Ground Clearance	L	mm	1,685	DRIVE SYSTEM				
Ground Pressure(empty)	kPa	35.4	ENGINE				HST				
Ground Pressure(Loaded)	kPa	59.7	Model	CAT C7.1 Tier 4 final Stage 5			GRADEABILITY				
MACHINE DIMENSION							Fully loaded: 27 % (15 degree) Continuous				
Machine Weight	Kg	16,000	Nominal Output/rpm	HP(kw)/rpm	252.9(186)/2,200		OTHER				
Overall Length	A	mm	Torque	N.m/min-1	1,214/1,400		Cabin (ROPS/FOPS) Joystick control Hardox Dump Body Auto Deceleration 360° Camera				
Overall Width	B	mm	HYDRAULIC PUMP								
Overall Height	C	mm	Main Pump		2x variable displacement axial piston pump						
Wheelbase	D	mm	Pilot pump		1x gear pump						
Min. Ground Clearance	E	mm	HYDRAULIC MOTOR								
Front Overhang	F	mm	Travel Motor		2x variable displacement axial piston motors						
Crawler Distance	G	mm	Swing Motor		1x axial piston motor						
Crawler Width	H	mm									
Crawler Size	mm	800x 150x 66									

Remarks: Specification may be changed without any notice.

MOROOKA EUROPE

Im Neugrund 14
64521 Gross-Gerau, Germany
Tel: +49 (0)61529778-0
Fax: +49 (0)61529778-15
Web: www.morookaeurope.com

Contact